

UL 580 CLASS 90 RATED PRODUCT ASSEMBLIES

CONSTRUCTION NO. 335 - Galvalume® BERRIDGE ZEE-LOCK PANEL WITH CONTINUOUS ZEE-RIB THROUGH 4" OF RIGID BOARD AND INTO 24 GAUGE STRUCTURAL METAL DECK

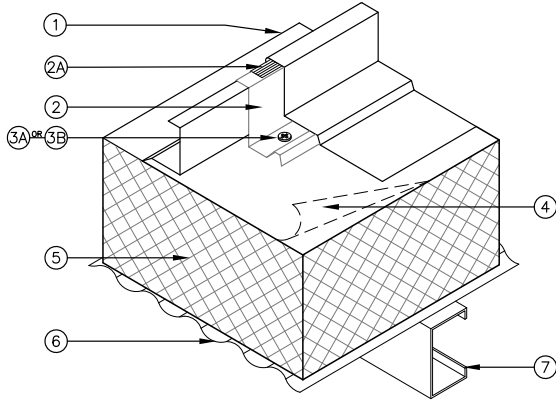

1. **BERRIDGE ZEE-LOCK PANEL:** No. 24 MSG (Min. yield strength 40,000 PSI) thickness coated steel, 16" wide, 2" high panel continuous over 2 or more spans without endlaps. Adjacent panels are seamed together alongside joints using an electric seamer tool.
2. **BERRIDGE CONTINUOUS ZEE-RIB:** One-piece assembly fabricated from No. 24 MSG (Min. yield strength 40,000 PSI) coated steel. Zee-Rib located at each panel side joint, continuous and equal to length of Berridge Zee-Lock Panels (Item 1).
 - a. Optional extruded vinyl weatherseal (U.S. Patent 5134825) may be used at panel side joints
3. **FASTENERS (SCREWS):**
 - a. **For Connection of Item #2 to Item #6:** #12 self-drilling steel screw through rigid board and connected to metal deck at 18" on center. Fastener length to be adjusted to account for thickness of rigid insulation and liner panel with $\frac{3}{4}$ " minimum penetration into metal deck.
 - b. **For Connection of Item #2 to Item #7:** #12 self-drilling steel screw per clip at each purlin location. Fastener length to be adjusted to account for thickness of rigid insulation, liner panel, and purlin with $\frac{3}{4}$ " minimum penetration into the purlin.
 - c. **For Connection of Item #6 to Item #7 (Not Shown):** #10 x $\frac{3}{4}$ " fastener spaced 5 $\frac{1}{2}$ " on center. Fasteners at side lap to be spaced 8" on center.
4. **FELT PAPER:** Two ply, No. 30 lb per 100 sq. ft.
5. **INSULATION:** Max. 4" thick, 2.25 pcf density 20 psi compressive strength rigid closed cell polyisocyanurate core fiberglass faced insulation.
6. **SUBSTRUCTURE (LINER):** No. 24 MSG (Min. yield strength 40,000 PSI) coated steel. Corrugation height to be minimum of $\frac{3}{4}$ ". endlaps to occur over purlins with panels overlapped minimum 4".
7. **PURLINS:** 16 MSG (Min. 50,000 PSI) coated steel. Spacing to be:
 - a. 5'0 on center when Item #2 is connected to Item #7
 - b. 4'0 on center when Item #2 is connected to Item #6

BERRIDGE MANUFACTURING COMPANY

2610 Harry Wurzbach Road, San Antonio, TX 78209 | 800-669-0009 | Fax 210-650-0379

Visit www.berridge.com for the most up-to date information. All information herein subject to change without notice. For technical assistance please contact Berridge.